



ACION 8000 Series

A8KEAM 1550nm (C-Band) EDFA Module

A8KEAM (C-Band) EDFA (Erbium-Doped Fiber Amplifier) module is designed for long-haul or wide broadcast optical fiber systems. It is a compact, highly reliable, scalable and cost-effective unit. The module is hot-swappable with integrated management through A8KPCM2 and remote management by HMS or SNMP. A maximum of 16 application modules can reside in the 19-inch, high-density chassis (A8KMF3). An output monitoring port is available for real-time monitoring without service interruption.

Features

- ◆ Operating frequency: 1540~1560 nm
- ◆ Optical input power from -5 to 8 dBm
- ◆ Optical output power from 17 to 23 dBm
- ◆ Single channel application
- ◆ SMF-28 Type Input / Optical Fiber
- ◆ Low noise figure
- ◆ Low power consumption
- ◆ Hot - swappable
- ◆ Remote control and monitor functions via HMS or SNMP

Block Diagram

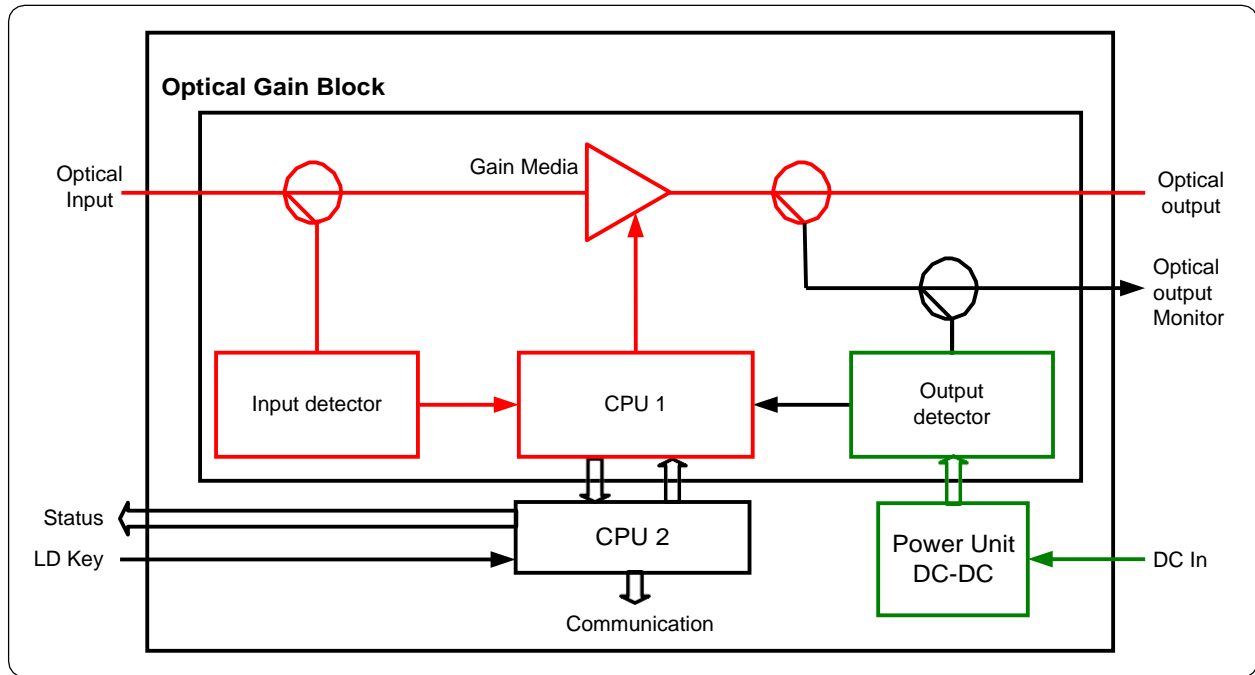

Application:

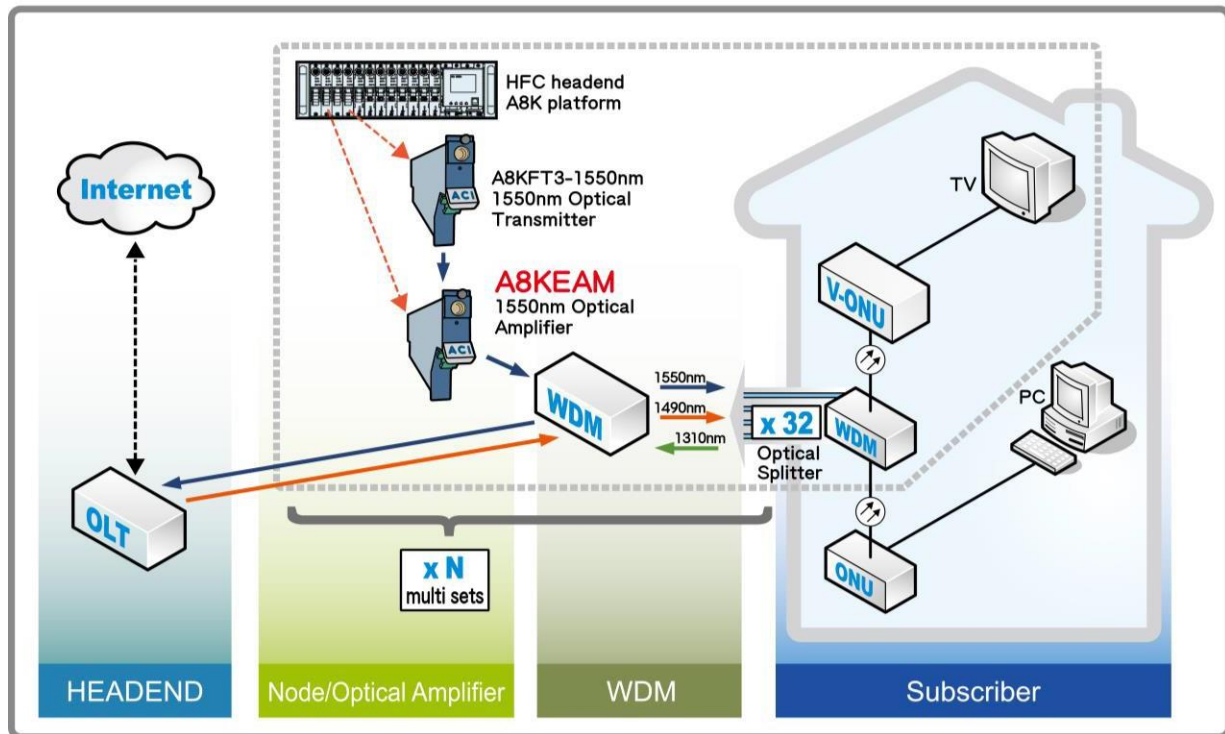

Specifications

ACI		ACION 8000 Series A8KEAM 1550 nm (C-Band) EDFA Module		
PARAMETERS	CONDITIONS	UNITS	SPECIFICATION	NOTES
Optical Specifications				
Optical Wavelength		nm	1540 to 1560	
Connector Type			SC/APC (standard) FC/APC, E2000/APC (optional)	
Optical Input Power		dBm	-5 to +8	
Optical Saturation Output Power		dBm	17 to 23	
Noise Figure	Pin = 0 dBm λ = 1550 nm	dB	5	
Optical Return Loss	Min.	dB	45	
Polarization Dependent Gain	Max.	dB	0.5	
Polarization Mode Dispersion	Max.	ps	1	
Input/Output Optical Fiber			SMF-28	
Electrical/Environmental/Mechanical				
Module Width		Slot	1	
Operating Temperature		°F (°C)	32 to 122 (0 to 50)	
Storage Temperature		°F (°C)	-40 to 149 (-40 to 65)	
Power Supply Voltage		V	24 ± 0.5	
Power Supply Current		A	1.2 @ 24 VDC	
Power Consumption	Max.	W	30	
Relative Humidity	Non-condensing	%	0 to 95	
Dimensions	W x D x H	Inch (mm)	16.1 x 5 x 1 (410 x 127 x 25.9)	
Alarm Functions				
Case Temperature High Alarm		°F (°C)	158 (70)	
Output high/low Alarm		dB	< -2 or > +2	
Input high/low Alarm		dBm	< -5 or > +8	
Pump LD Bias High Alarm		mA	> LD Link Current	LD Shut Down ★1
Pump LD Temp. High Alarm		°F (°C)	> 80.5 (27)	
Pump LD Shutdown by Input Power		dBm	< -12	

★1: LD Output Shut Down Function by LD Bias high, LD Temperature high, or low Input Power.

Ordering Matrix

A8KEAM 1550nm (C-Band) EDFA Configuration Sheet

Customer: _____

Created By: _____

ORDERING MATRIX

2010/5/13

Position		1	2	3	4
PART NUMBER	A8KEAM-1550nm	—		—	

1-2 Output Power

1	7	= 17 dBm
1	8	= 18 dBm
1	9	= 19 dBm
2	0	= 20 dBm
2	1	= 21 dBm
2	2	= 22 dBm
2	3	= 23 dBm

3.4 Connector

S	C	= SC/APC with shutter (standard)
F	C	= FC/APC (option)
E	C	= E2000/APC (option)

NOTES:



ACI Communications, Inc.
23307 66th Avenue South
Kent, WA 98032

Rev G 6-14-2019 Printed in U.S.A.
ACI Communications, Inc. reserves the right to discontinue the manufacture or change specifications without prior notice on any parts illustrated in this data sheet. Registered trademarks are the property of their respective owner